

### 1. PRECAUTION

Please read through this Manual before use the instrument for correct handling. Please keep this Manual carefully after use. This instrument has been thoroughly tested at the factory before shipment. When you receive it, visually inspect it for damage and check the accessories.

- ① Model number and specification check  
Check to see the model number and specifications on the nameplate attached to the front face of the instrument are as ordered.
- ② Contents of instruction manual  
This instruction manual provides instructions on handling, external wiring and safety use of instrument.

### 2. GENERAL

This compact plug-in type tachometer transmitter receives single phase AC current or voltage signal from tachometer and converts it into isolated voltage or current signal.

Accessories:

- Spacer ..... 1  
(Use for DIN rail mounting)

### 3. MOUNTING METHOD

JUXTA M Series signal conditioners can be mounted on wall or DIN rail.

#### 3.1 Wall mounting

Unlock stoppers and remove the transmitter from socket as shown in Fig.1. Then, fix the socket on the wall. Take installation gap as shown in Fig.3. (Refer Fig.3 for mounting dimensions).

#### 3.2 DIN rail mounting

Insert DIN rail into upper section of the DIN rail groove on rear of socket of transmitter and fix the rail with slidlock at the base of the transmitter as shown in Fig.2. Use furnished spacer and take 5mm gap between transmitters.

#### 3.3

If the wiring duct is used, install it aparting more than 20mm from top face of main body.

### 4. EXTERNAL WIRING

**CAUTION** Wiring should be done after ensuring power break of each cable.

See Fig.4 for terminal arrangement.

Wires should be connected to M3.5 screw terminals on socket. For wiring, flexible twisted wires and good contact of durable round crimp-on terminals are recommended to be used.

- Signal cable should has more than 0.5mm<sup>2</sup> and power cable should has more than 1.25mm<sup>2</sup> of nominal cross-sectional area of conductor.

#### 4.1 Wiring

- ① Connect input signal cable to transmitter terminals 3(V), 4(±).
- ② Connect output signal cable to terminals 1(+) and 2(-).
- ③ Connect power cable to terminals 7(L+), 8(N-) and ground to 6(GND).

**NOTE :** Apart wiring of power and input/output cables from noise source. Otherwise, accuracy may not be warranted.

Fig.1 Wall Mounting

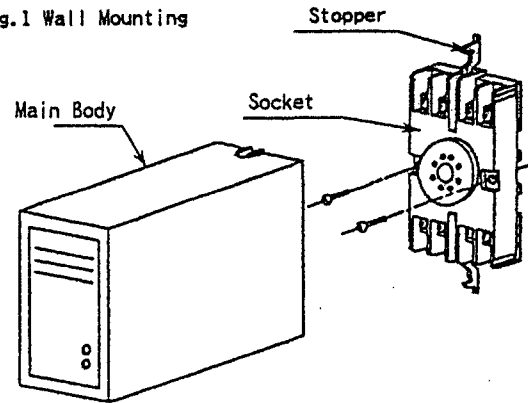
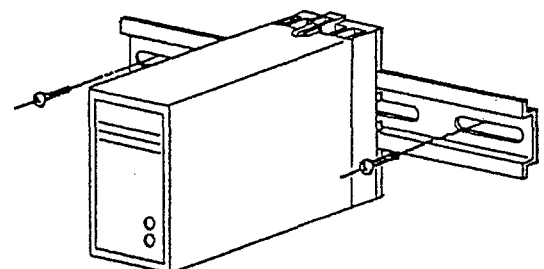
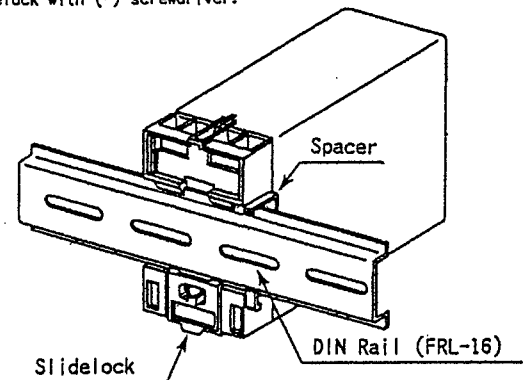

Fig.2 DIN Rail Mounting

To remove transmitter from DIN rail, lower the slidlock with (-) screwdriver.



## 5. INSTALLATION AND HANDLING

- ① Avoid installation in such environments as shock, vibration, corrosive gas, dust, water oil, solvent, direct sunlight, radiation, powerful electric and magnetic fields.
- ② In order to protect instrument from inducement of thunder surges in power and signal cables, use arrester between transmitter and equipment installed in the field.

## 6. SAFETY USE

Following caution for safety should be taken for handling of instrument. We are not responsible for damage incurred by use contrary to caution.

### CAUTION

- Be sure to lock the stoppers (top and bottom) after inserting the main body into socket.
- Following items should be checked when turning power on. Use of instrument ignoring specifications may cause overheat or burning.
  - (a) Voltage of power supply and input value be applied to the instrument should meet with required specifications.
  - (b) External wiring to terminals should be connected correctly. (See preceding Article 4)
- Do not use the instrument in such dangerous places where exist inflammable and explosive gas or steam.
- As for instrument having power supply of 85~264V AC, these voltages are internally charged in main body. Do not open front cover.

## 7. MAINTENANCE

10~15 minutes warm up is required to satisfy the specifications of the instrument.

### 7.1 Calibration Equipment

- AC Voltage/Current Generator 1  
(Yokogawa Model 2558 or equivalent)
- Voltmeter 1  
(Yokogawa Model 2502A or equivalent)
- Precision Resistor 250Ω ±0.01% 1W 1

### 7.2 Calibration

- ① Connect each equipment as shown in Fig.6.
- ② Input/output characteristics check  
Apply input signals equivalent 0, 25, 50, 75, 100% of input span to transmitter through Voltage/Current Generator.  
Check that corresponding transmitter outputs are 0, 25, 50, 75 and 100% respectively and are within accuracy rating range.  
Use R for current output only.
- If output signal is out of tolerance, adjust it through span and zero adjustment trimmer on front panel of transmitter.

Fig.3 Mounting Dimension

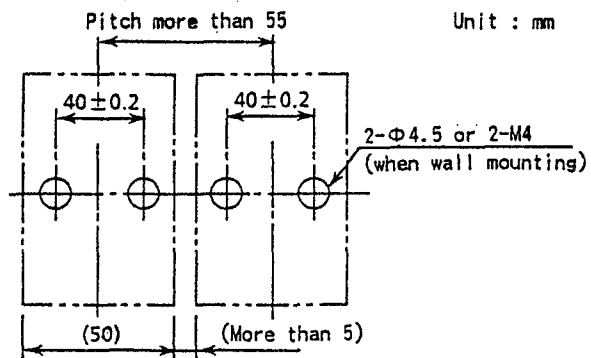
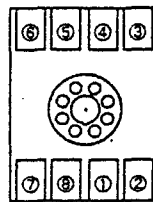

Fig.4 Terminal Arrangement



TML	
1	OUTPUT +
2	OUTPUT -
3	INPUT v
4	INPUT ±
5	
6	GND
7	SUPPLY L+
8	SUPPLY N-

Fig.5 Wiring Diagram

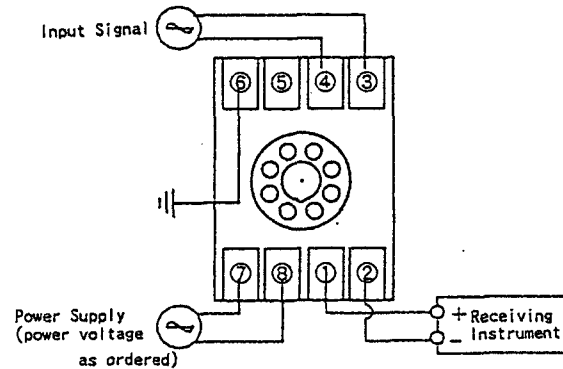
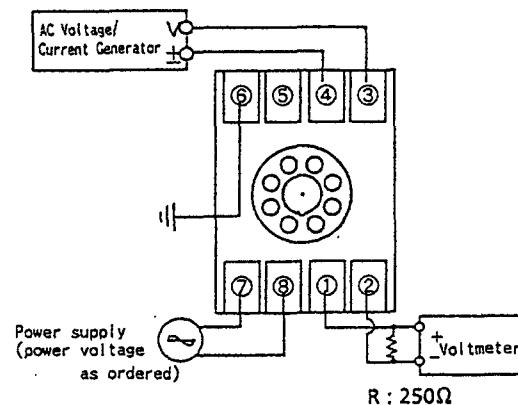

Fig.6 Wiring of Calibration Equipment



Subject to change without notice for grade up quality and performance.